Shafts Which Cannot Be Rotated

Introduction

This TechNote describes how to take alignment readings on machines where one or both shafts cannot be rotated manually. The procedure requires the use of the ALI 2.112 Magnetic Bracket with L 220 Position Adapter, or the ALI 2.230 Magnetic Sliding Bracket, that are available from Ludeca or through the ROTALIGN® PRO representative in your area.

Anytime a shaft cannot be turned, the quality of the alignment readings will always be at the mercy of the surface irregularities or eccentricities of the shaft or hub on which the sliding bracket is mounted. It is imperative that these surfaces be as concentric and defect-free as possible. Always bear in mind that accuracy and repeatability can never be as good as when you actually turn both shafts to take readings.

Overview

When one of the shafts cannot be manually rotated while the other (if uncoupled) *can* be turned, mount the Laser on the shaft which can turn, and install the Receiver on the shaft which cannot be turned. The Receiver is traditionally mounted on the right machine (the 'Machine To Be Moved' or MTBM). However, If it happens that the shaft which cannot turn belongs to the Stationary machine, mount the Receiver on it anyway, and simply use the ROTALIGN® PRO's Static Feet function to make the right machine stationary and instead view results for moving the left machine. In other words, no matter what the situation, the machine whose shaft cannot be rotated will always be the right machine with the Receiver mounted on it, and, if necessary, the static feet function takes care of which machine is stationary and moveable for alignment purposes.













Center the beam, start Pass Mode, position the Receiver and rotate the Laser past it. Reposition the Receiver without letting the beam enter it, and rotate the Laser past it again. Repeat this enough times to get adequate rotation angle and number of readings. Never slide the Receiver through the beam to take readings. Repeat the entire measurement set several times to establish repeatability and average results together in the Measure Table if necessary.

If neither shaft will turn, center the beam in the Receiver, select Multipoint Mode, and take a point. Slide each bracket separately to a new common position and take another point. Repeat until at least 8 and preferably 16 points well distributed around the circumference of the coupling hubs have been taken. Repeat the entire measurement set several times to establish repeatability and average results together in the Measure Table if necessary.

Procedures

If one shaft can turn and one cannot:

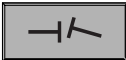

- 1) Mount the Laser on the shaft which can turn.
- 2) Mount the Receiver on the solid coupling hub of the shaft which cannot turn, using an ALI 2.230 Magnetic Sliding Bracket, or an ALI 2.112 Magnetic Bracket with L 220 Position Adapter. The shaft with the Receiver will still be called the Right Machine, even if it happens to be the Stationary Machine. If this is the case, see the note in step 5.

- 3) Turn on your ROTALIGN® PRO  .
- 4) In Program Manager, select the Align Shafts application () with the  softkey.
- 5) Configure your left and right machine setups as needed and enter all necessary dimensions normally.
Note: If the right machine is to be considered stationary and the left machine moveable, configure the left machine support as something other than 'stationary' and then use the static feet function as needed. (For detailed instructions on how to do this refer to Appendix A.)
- 6) Turn on the Laser, press  and center the beam in the Receiver.
- 7) Press  , select Pass Mode (uncoupled shafts), then press  .
- 8) Press  .
- 9) Cover the Receiver with its dust cap to block the beam.
- 10) Reposition the Receiver's bracket at a different position around the coupling hub.
- 11) Remove the Receiver's dust cap.
- 12) Rotate shaft with the Laser past the Receiver. Observe that the green diode on the Receiver lights as the Laser passes the Receiver.
- 13) Repeat steps 9 through 12 several more times. (At least 8 passes and preferably more are recommended, well distributed around the circumference of the coupling hub.)
- 14) Press  .
- 15) It is highly recommended that you repeat the sequence of steps 8 through 14 at least 3 more times, but press  in step 14 after the last set of readings to check repeatability in the Measure Table. (If you wish, you may average multiple rows of results together for more accuracy prior to step 16. Highlight desired rows with the  or  softkeys, and select (or unselect) them for averaging with the  softkey, observing that the checkmark symbol appears by the rows that you want to average together. When finished press  .)
- 16) Press  to obtain results and proceed with the alignment by shimming and moving the moveable machine as needed.

If neither shaft can turn:

1) Mount Laser on the solid coupling hub of the left machine and Receiver on the solid coupling hub of the right machine, using ALI 2.230 Magnetic Sliding Brackets or ALI 2.112 Magnetic Brackets with L 220 Position Adapters.



2) Turn on your ROTALIGN® PRO .

3) In Program Manager, select the Align Shafts application () with the  softkey.

4) Configure your left and right machine setups as needed and enter all necessary dimensions normally.

5) Turn on the Laser, press  and center the beam in the Receiver.

6) Press , select Multipoint Mode, then press .





Note: At this point, you may also wish to set the averaging rate for multipoint readings by accessing averaging from the XY View screen. To do this press  then .



7) Press .

8) Slide both brackets to a new common position on their hubs and repeat step 7.

9) Repeat step 8 until at least 8 and preferably 16 points have been taken around the circumference of the hubs.

10) Press .

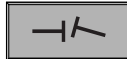
11) It is highly recommended that you repeat the sequence of steps 7 through 10 at least 3 more times, but press  in step 10 after the last set of readings to check repeatability in the Measure Table. (If you wish, you may average multiple rows of results together for more accuracy prior to step 16. Highlight desired rows with the  or  softkeys, and select (or unselect) them for averaging with the  softkey, observing that the checkmark symbol appears by the rows that you want to average together. When finished press .)

12) Press  to obtain results and proceed with the alignment by shimming and moving the moveable machine as needed. 

Note: ROTALIGN® PRO is a registered trademark of Prüftechnik A.G.

Appendix A

Configuring the left machine moveable and right machine stationary

Suppose you begin with the following standard new machine setup, where the left machine is stationary and the right machine is moveable (see Figure 1):

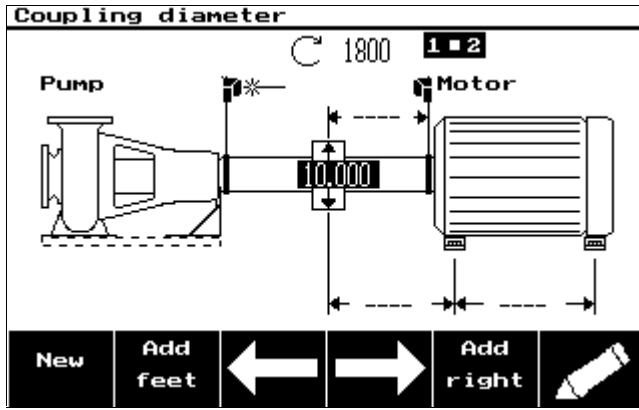

Figure 1

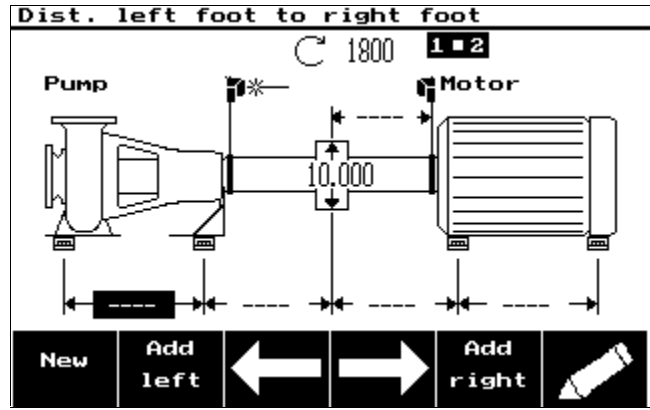

Figure 2

- 1) The first step is to press the **Add feet** softkey. This automatically configures the left machine as a moveable four-footed machine (see Figure 2). Then enter all necessary dimensions.

Note: For other setup alternatives simply select Machine Type from the main Menu and configure all of the characteristics of the left machine as desired.

- 2) Press **MENU**, select the Static Feet option with **↓** softkey and press **OK**.

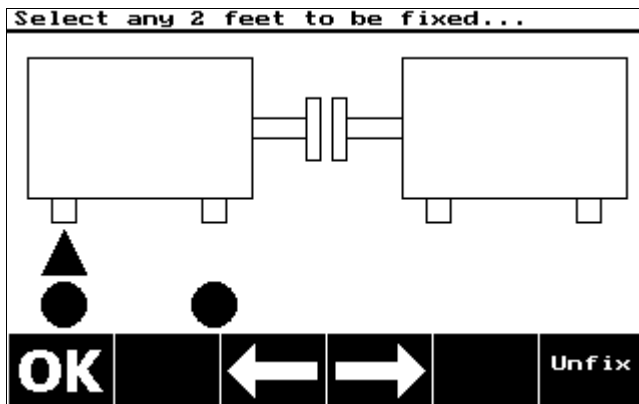

Figure 3

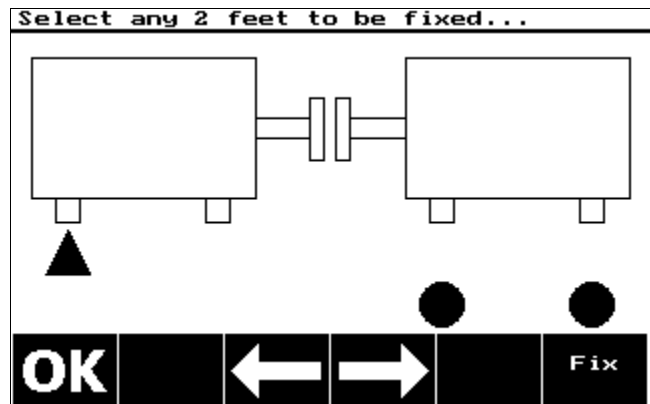

Figure 4

- 3) Use the **←** and **→** softkeys to move the triangle cursor under any foot and fix or unfix the foot using the **Fix** and **Unfix** softkeys as needed to make the left machine feet moveable and the right machine feet static (see Figures 3 and 4). A black circle under a foot signifies it is fixed, or static. Press **OK** when finished. ☐