

Machine with Staggered or Extra Support Feet

This note is intended for situations when the MTBM has staggered support feet or more than two sets of feet.

Normally Optalign will display corrections for the inboard feet (front feet) and the outboard feet (back feet). There may exist other feet between front and back feet. Corrections for these other feet can be obtained from Optalign. It should be noted that Optalign does not distinguish whether at a given distance from the laser there exists one, two or more feet. So, for a given foot location, the depicted front foot could be one, two or more feet.

If the front foot-to-back foot distance is changed, the Optalign will recalculate the feet corrections accordingly. Thus, if a machine has feet between the front and back most feet, then change the front-foot-to-back-foot distance to place the Optalign back foot on one of the inner feet. The shim and move values for the new back foot location will be displayed.

For the move function, any two feet at different distances away from the laser could be picked to monitor horizontal corrections. The distances should be picked so that the move is aided by the depiction in the Optalign screen.

Overview

- LP and LF are entered into the Optalign in the usual manner.
- FB is entered as the distance from inboard foot (feet) to the nearest next foot (feet). Alignment readings are taken in at least 3 clock positions.

- Press **RUN** and record feet corrections. These will be the corrections for the first two sets of feet.
- Press **RCL**. Optalign will display the FB depiction.
- Change the displayed value to the distance between the inboard foot (feet) and the third foot (feet), press **ENT**
- Press **RUN**. Optalign will display front foot vertical, inboard foot (feet). This value should be the same as previously recorded. Press **BK_{FT}** and Optalign will display the vertical correction for the third foot. Press **H/V**, **BK_{FT}** to obtain the horizontal move for the third foot.

Repeat these steps as many times as necessary.

Horizontal Move should be carried out with FB as the distance between inboard feet and the farthest outboard feet. Loosen **all** bolts slightly and proceed to move as in a regular four footed machine.

LP = Laser-to-prism
 LF = Laser-to-Front
 Foot (Foot 1)

FB2 = Distance
 between Foot 1 and
 Foot 2
 FB3 = Distance
 between Foot 1
 and Foot 3
 FB4 = Distance
 between Foot 1
 and Foot 4

VF = Shimming at
 Foot 1
 HF = Horizontal Move
 Foot 1
 VB2 = Shimming at
 Foot 2
 VB3 = Shimming at
 Foot 3
 VB4 = Shimming at
 Foot 4
 HB2 = Horizontal Move
 at Foot 2
 HB3 = Move at Foot 3
 HB4 = Move at Foot 4

VO = Vertical Offset
 HO = Horizontal Offset
 VA = Vertical Angularity
 HA = Horizontal
 Angularity

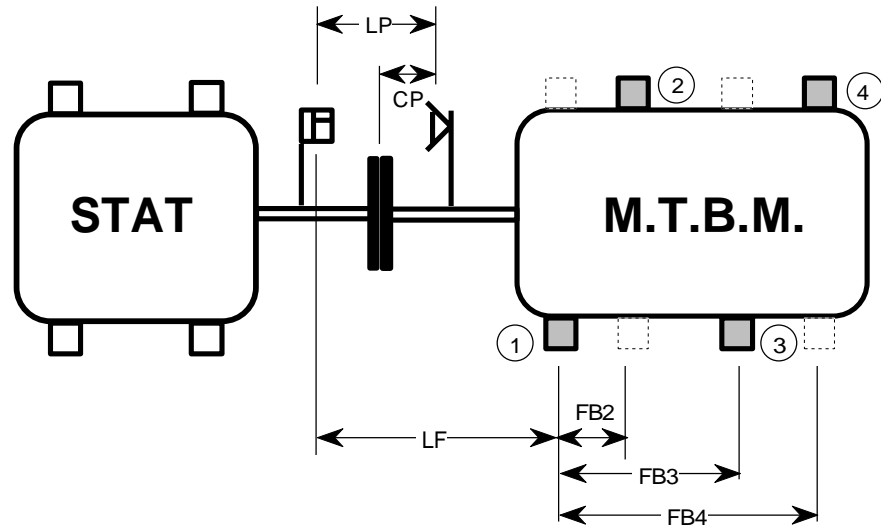

Procedure

- 1) **ON**, **/**, **ENT**
- 2) Enter LP, **ENT**
- 3) Enter LF, **ENT**
- 4) Enter FB2, **ENT**
- 5) Take alignment readings in at least 3 clock positions.
- 6) **RUN**, record VF, VB2, HF, HB2.
- 7) **RCL**
- 8) Enter FB3, **ENT**
- 9) Record VB3, HB3 (given as back foot correction).
- 10) **RCL**
- 11) Enter FB4, **ENT**
- 12) Record VB4, HB4 (given as back foot correction).
- 13) **□□□**
- 14) Enter CP, **ENT**
- 15) Enter 10" DIA. **1**, **0**, **ENT**
- 16) **RCL**, **RCL**, **RCL**
- 17) Record VO, HO, VA, HA.
- 18) If alignment is not within tolerance, corrections must be made.
- 19) **RUN**, **RCL**

20) Enter FB2, **ENT**

21) Proceed to shim all feet according to VF, VB2, VB3, VB4.

22) Repeat steps 3 to 17 as required.

Horizontal Move

If, from step 18, you decide to make a horizontal move;

19) **RUN**, **RCL** and enter front-to-back-foot distance to match jackbolts or outboard bolts. **MOVE**

20) Zero system at 1:30.

21) **MOVE**

22) Proceed to move until values in the Optalign display approach zero.