

## Right Angle Gearbox

This procedure is to align a gearbox connected to a vertical shaft when corrections have to be made at the gearbox feet.

For such set up, the gearbox becomes the MTBM and the feet are visualized as being the bolt circle where the shimming will be performed to correct shaft angularity.

### Overview

Set up laser on stationary shaft and prism on gearbox shaft. Enter actual laser to prism distance. Enter as laser to front foot the distance between laser to coupling center. Front to back foot as the distance between diagonally opposing bolts. If gearbox shaft is not at the center of gearbox, measure from the shaft centerline to the farthest bolt. Enter *twice* that distance as distance front to back foot. Choose the 12 o'clock position to be half way between any two consecutive feet.

Since the inclinometer does not work in the vertical alignment 0, 3, 6, 9 have to be controlled by some other method. Take alignment reading in at least 3 clock positions. Press **RUN** and then coupling. Enter distance prism-to-coupling and coupling diameter (10"). Record misalignment values. If angularity is not within tolerance press **F**, **5** to obtain correction values for the gearbox feet.

Perform corrections opposite to the values displayed by Optalign for that foot. If Optalign recommends to add shims, then remove shims.

An alternate way will be to carry out Optalign suggested corrections on the foot diagonally opposite (if such a bolt exists). Once angularity is within tolerance, correct offsets, if any, following Tech Note 16.

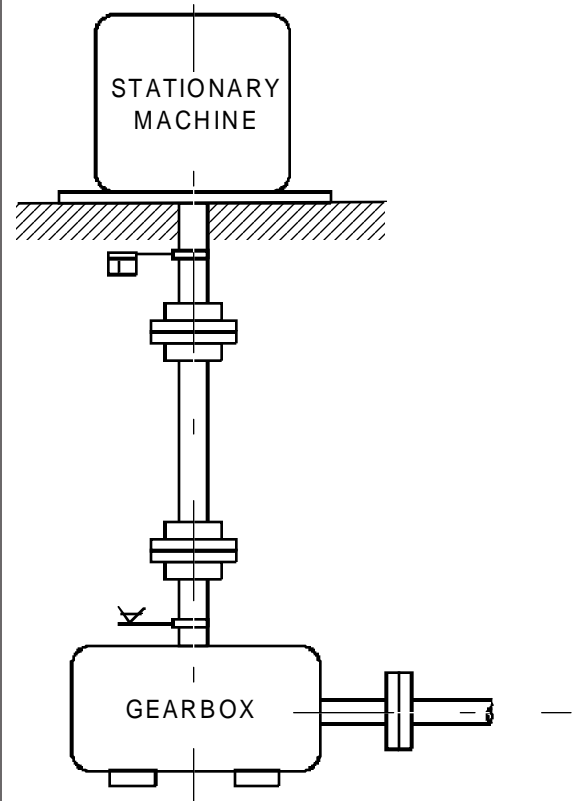

## Procedure

Choose 12 o'clock position to be between two consecutive bolts. Each 90° increment clockwise will be the 3, 6, 9 o'clock positions respectively. Set laser on stationary and prism on gearbox shaft.

$DIA = \text{Coupling diameter}$

$VO = \text{Vertical Offset}$   
 $HO = \text{Horizontal Offset}$   
 $VA = \text{Vertical Angularity}$   
 $HA = \text{Horizontal Angularity}$

- 1) Enter laser-to-prism: actual distance between laser and prism, **ENT**
- 2) Enter laser-to-front-foot: distance between laser and coupling center, **ENT**
- 3) Enter front-to-back-foot: distance between diagonally opposing bolts. **ENT**

Note: If gearbox shaft is not at the center of gearbox, measure distance between shaft centerline and center of farthest foot, enter **twice** that distance as front-to-back-foot.

- 4) Zero system at 12 o'clock and take alignment readings.
- 5) **RUN**, ignore feet corrections.
- 6) **□**, enter distance prism-to-coupling-center, **ENT**
- 7) Enter 10" DIA. **1**, **0**, **ENT**
- 8) Press **RCL**, **RCL**, **RCL**
- 9) Record coupling results (VO, HO, VA, HA).

If VA or HA are **not** within tolerance follow step 10. If VA and HA are within tolerance follow step 17

- 10) Press **F**, **5** Optalign will take a few seconds to display.

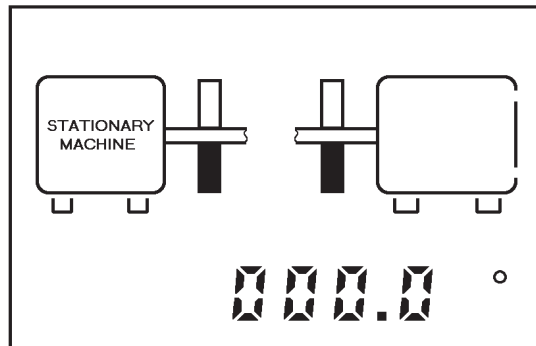

Now the angular position of the first foot away from 12 o'clock must be entered. For the corresponding diameter keyed as front-to-back-foot distance. See examples on how to calculate this angle.

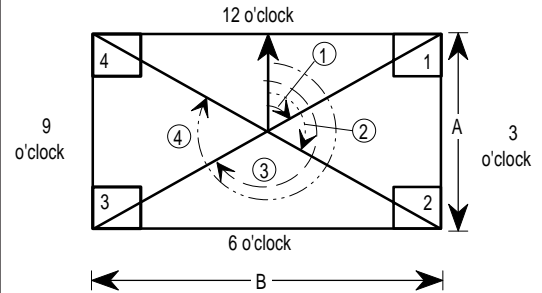

### Example 1:

Gearbox shaft in center of gearbox.

Tangent ① =  $B \div A$ ; find the value of angle ① using a calculator. (INV TAN at  $B \div A$ )

say,

Angle ① =  $\alpha$ , therefore

Angle ② =  $180 - \alpha$

Angle ③ =  $180 + \alpha$

Angle ④ =  $360 - \alpha$

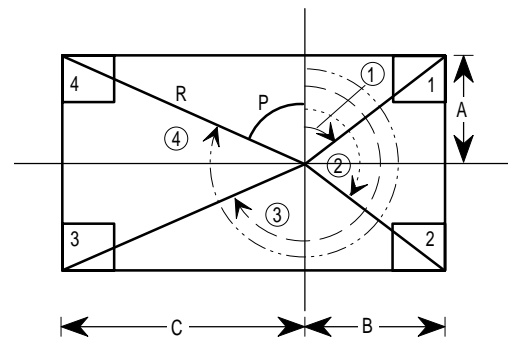

## Example 2:

Gearbox shaft centerline *not* at center of gearbox.

Enter front to back foot distance = 2R  
Tangent ① = B ÷ A, find the value of angle 1 using a calculator.

Angle ① =  $\alpha$   
Angle ② =  $180 - \alpha$   
To calculate angles ③ and ④ we must first calculate angle P; then

Angle ③ =  $180 + \text{angle P}$   
Angle ④ =  $360 - \text{angle P}$   
Tangent  $p = C \div A$ ; find the value of angle P using a calculator.

*Make sure that the angle that corresponds to the diameter entered at front foot to back foot distance. To change the diameter see step 13.*

11) Enter angle, Optalign will display correcting values (shimming) for that foot.

12) **ENT**

13) **CLR**, enter new desired angle. Optalign will display correcting values (shimming) for that foot.

Note: If necessary, from the angle depiction press **RCL** to change the diameter entered as front-to-back-foot. Enter new diameter, **CLR** displayed angle and enter desired angle. Optalign will display correction values (shimming) for the foot corresponding to the diameter entered as front-to-back-foot distance.

14) Repeat steps 11 to 13 until corrections for all feet are obtained.

15) Proceed to shim each foot opposite to Optalign's suggested correction.

Positive shimming: remove shims

If not enough shims to remove under a foot, it is possible to add equal amount of shims to **all** feet and then carry out corrections.

16) Recheck alignment.

17) When VA and HA are within specs, press **RUN** to obtain the moves.

Vertical front foot correction: move in the 12-6 o'clock plane.

18) **H/V**. Horizontal front foot correction: move in the 3-9 o'clock plane.

Use Tech Note 16 to monitor the move.