

## Extended Overhung Shaft

This tech note applies to shafts which extend unsupported a considerable distance beyond the machine housing. Typically, the shaft's own weight and the weight of a coupling combine to cause considerable sag in the shaft. Since the mechanical arrangement is common in overhead cranes and hoists, this note refers specifically to crane gearcase applications. The same approach could apply to a variety of other machines of course.

This procedure assumes the gearcase has tight bearings (ball, roller, etc.). If not, then the overhung shaft will rest on the bottom of one gearbox bearing and on the top of the other.

If this is the case, then the outboard end of the shaft should be held or supported down so that the shaft rests on the bottom of both bearings. If it is not possible to properly support the shaft, then the bearing gap (radial clearance) must be measured and the formulas used to calculate targets in step 12 adjusted to account for bearing clearance.

LP = Laser-to-prism  
 LF = Laser-to-Front  
 Foot  
 FB = Front-to-back foot  
 CP = Coupling center -  
 to- prism  
 DIA = Coupling  
 diameter

VOt = Vertical Offset  
 target  
 HOt = Horizontal Offset  
 target  
 VAAt = Vertical Angularity  
 target  
 HAAt = Horizontal  
 Angularity target

VO = Vertical Offset  
 HO = Horizontal Offset  
 VA = Vertical Angularity  
 HA = Horizontal  
 Angularity

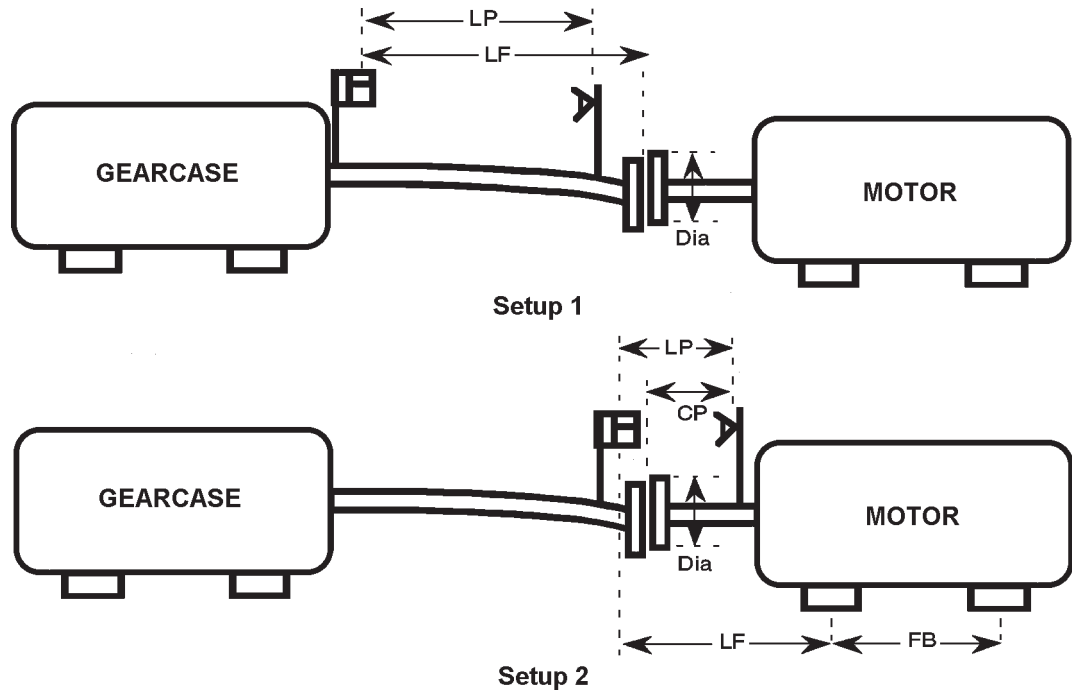

## Procedure

- 1) Disconnect coupling and allow shafts to hang freely.
- 2) Set up laser on gearcase shaft close to the gearcase bearing. (See Setup 1 above).
- 3) Set up prism on gearcase shaft close to its coupling half.
- 4) **ON**, **/**, **ENT**
- 5) Enter machine dimensions as follows:  
 LP = laser-to-prism, **ENT**  
 LF = laser-to-coupling center, **ENT**  
 FB = 0 **0**, **ENT**
- 6) Press **M** and zero system.
- 7) Take alignment readings.
- 8) **RUN**, the first reading is the shaft sag. Record this value for use in step 11.
- 9) Set up laser on prism's bracket facing motor. Set up prism on motor shaft This will give a normal shaft alignment setup. (See Setup 2 above).
- 10) **RCL**, **RCL**, **RCL**, enter machine dimensions as shown in Setup 2.
- 11) Press **□**, then enter the following:  
 CP = coupling center-to-prism as shown in Setup 2 **ENT**  
 DIA = 10" **1**, **0**, **ENT**
- 12) Enter targets as follows:  
 VOt = positive value of sag, **ENT**  
 HOt = zero, **0**, **ENT**  
 $VAAt = 1.4 \times \text{negative sag value} \times 10$ , **ENT**  
*laser to prism distance*  
*This laser to prism distance should be the one entered in step 5.*  
 HAAt = zero, **0**, **ENT**
- 13) Press **M** and zero system.
- 14) Take alignment readings.
- 15) **RUN**, record foot corrections.
- 16) **□**, **RCL**, record coupling results (VO, HO, VA, HA).
- 17) Carry out corrections. Always make largest motor adjustments first. If any motor adjustment output values are much larger than the other values, make large adjustment and repeat steps 9 to 17, until the alignment is within tolerance.

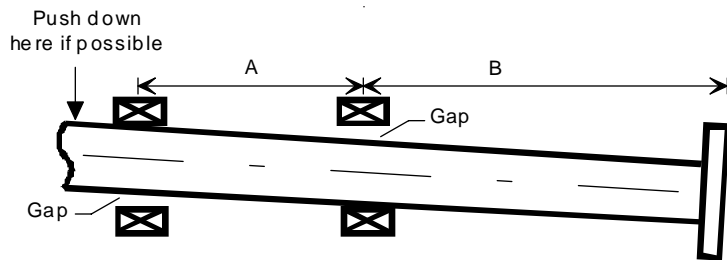

Figure 1

### Note

This procedure assumes the gearcase has tight bearings (ball, roller, etc.). If not, then the overhung shaft will rest on the bottom of one gearbox bearing and on the top of the other. See Figure 1.

If this is the case, then the outboard end of the shaft should be held or supported down so that the shaft rests on the bottom of both bearings. If it is not possible to properly support the shaft, then the bearing gap (radial clearance) must be measured and the formulas used to calculate targets in step 12 adjusted to account for bearing clearance.

VOt =

$$\left(\text{positive value of sag}\right) + \left(\frac{B}{A} \times \text{gap}\right)$$

VAt =

$$\left(\frac{1.4 \times \text{negative sag value}}{\text{laser to prism distance}} \times 10\right) - \left(\frac{\text{gap}}{A} \times 10\right)$$